

# Undercounter Refrigerators

## Unique Energy Saving Design



### FEATURES / BENEFITS

■ **EFFICIENT REFRIGERATION SYSTEM**

M3's solid door refrigerators are designed with oversized and balanced (CFC Free R-134A) refrigeration systems. These include efficient evaporators and condensers for faster cooling and greater efficiency.

■ **STAINLESS STEEL LOUVER**

Built to withstand food acids and stains, stainless steel louvers ensure even distribution of cold air throughout the interior of the unit.

■ **STAINLESS STEEL CABINET CONSTRUCTION**

The Turbo Air M3 model boasts a stainless steel interior and exterior (except inside wall and the back). It guarantees the utmost in cleanliness and long product life. The M3 can add a touch of style to the most refined setting.

■ **HIGH-DENSITY POLYURETHANE INSULATION**

The entire cabinet structure and solid doors are formed-in-place using high density, CFC free polyurethane insulation.

■ **ADJUSTABLE, HEAVY DUTY, PE(POLYETHYLENE) COATED WIRE SHELVES**

■ **ERGONOMICALLY DESIGNED DOOR**

Customers' fatigue fades away with easy grip handles and doors that open effortlessly. These features along with self-closing doors make this the ultimate choice in customer convenience. ABS sheet door liners resist water condensation with thermal efficiency.

■ **MAGNETIC DOOR GASKET**

Magnetic door gaskets are of one piece construction, removable without tools for ease of cleaning and replacement.

■ **HOT GAS CONDENSATE SYSTEM**

Through Turbo Air's creative innovation, the condensate system surfaces have been specially treated to resist corrosion. This not only increases efficiency without the risk of refrigerant leakage from corrosion, but also prevents the overflow of condensate water.

■ **REFRIGERATOR HOLDS 33°F ~ 38°F FOR THE BEST IN FOOD PRESERVATION**

\* Height does not include 6" for caster height.

Model	Swing Door	CU./FT.	#of Shelves	HP	AMPS	Crated Weight	L D H
MUR-28	1	7	1	1/3	6.6	159	27 1/2 x 30 x 30 1/3
MUR-36	2	11	2	1/3	6.6	190	36 1/3 x 30 x 30 1/3
MUR-48	2	12	2	1/3	6.5	234	48 2/9 x 30 x 30 1/3
MUR-60	2	16	2	1/3	8.9	278	60 1/4 x 30 x 30 1/3
MUR-72	3	19	3	1/2	9.9	324	72 2/3 x 30 x 30 1/3

# MUR-28 / MUR-36 / MUR-48 / MUR-60 / MUR-72 SPECIFICATIONS

MODEL	MUR-28	MUR-36	MUR-48	MUR-60	MUR-72
Exterior Dimension (LxDxH)	27 1/2x30x30 1/3	36 1/3x30x30 1/3	48 2/9x30x30 1/3	60 1/4x30x30 1/3	72 2/3x30x30 1/3
Cubic Feet	7	11	12	16	19
Compressor (HP)	1/3	1/3	1/3	1/3	1/2
Shelves	1ea	2ea	2ea	2ea	3ea
Net Weight	150lbs	179lbs	221lbs	262lbs	306lbs
Voltage (i) NEMA 5-15P	⓪115V / 60Hz	⓪115V / 60Hz	⓪115V / 60Hz	⓪115V / 60Hz	⓪115V / 60Hz
Amp	6.6A	6.6A	6.5A	8.9A	9.9A
Cord Length	9.2 ft.	9.2 ft.	9.2 ft.	9.2 ft.	9.2 ft.
Plug-In	NEMA 5-15P	NEMA 5-15P	NEMA 5-15P	NEMA 5-15P	NEMA 5-15P

- **SELF-CONTAINED SYSTEM**
- **5" SWIVEL CASTERS**
- **STAINLESS STEEL BACK SPLASH (OPTION)**
- **LEGS AVAILABLE FOR ALL MODELS (OPTION)**
- **REMOTE CABINETS AND CONDENSING UNITS AVAILABLE FOR ALL MODELS.**

\*Design and specifications subject to change without notice.

- **WARRANTY : 1 Years Labor and Parts Warranty  
Additional 4 Years Warranty on Compressor**



(unit : inch)

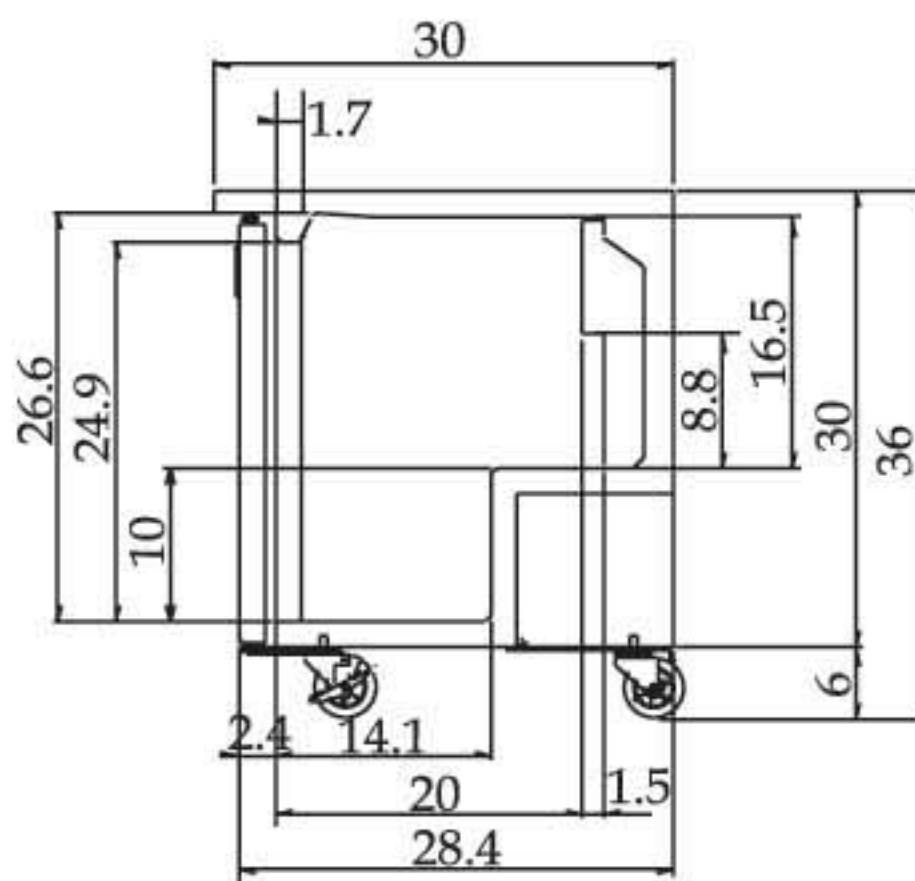

**SIDE VIEW**

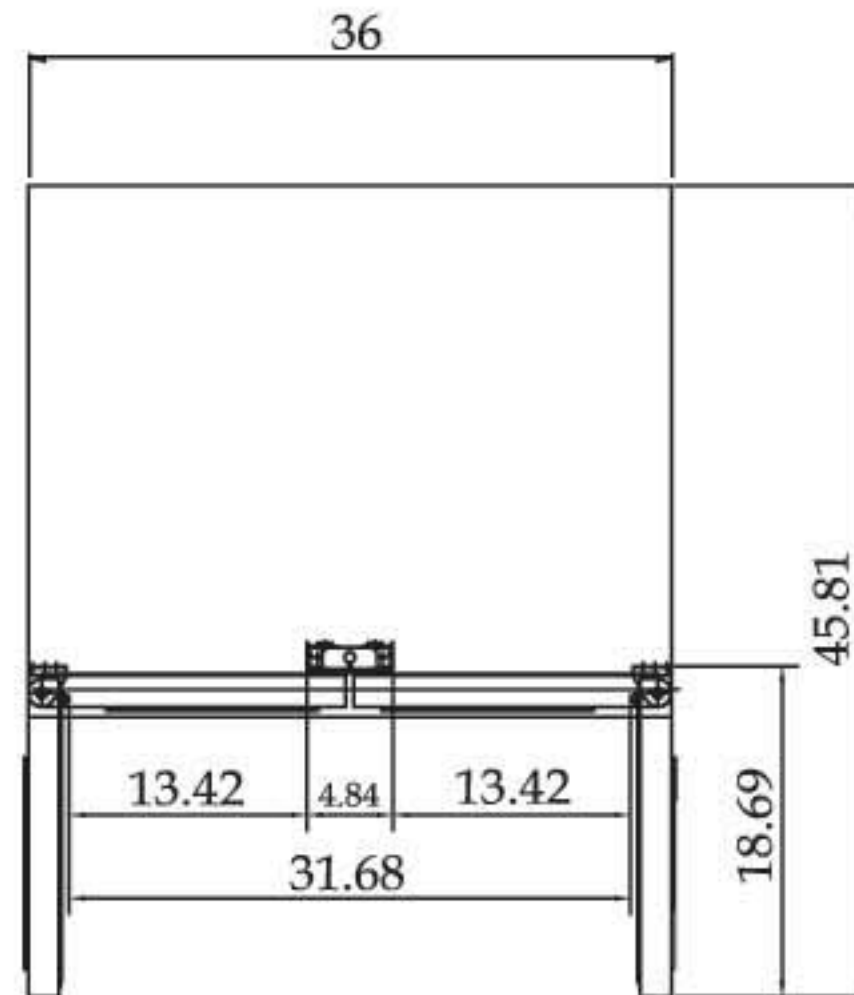

**MUR-36 PLAN VIEW**

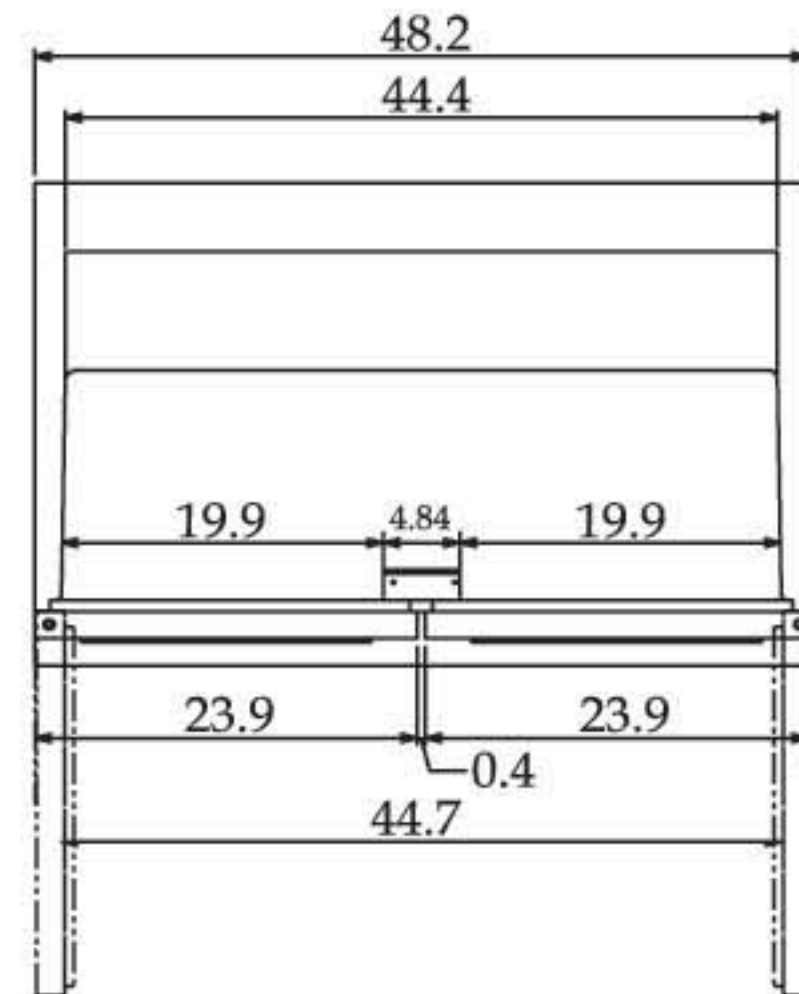

**MUR-48 PLAN VIEW**

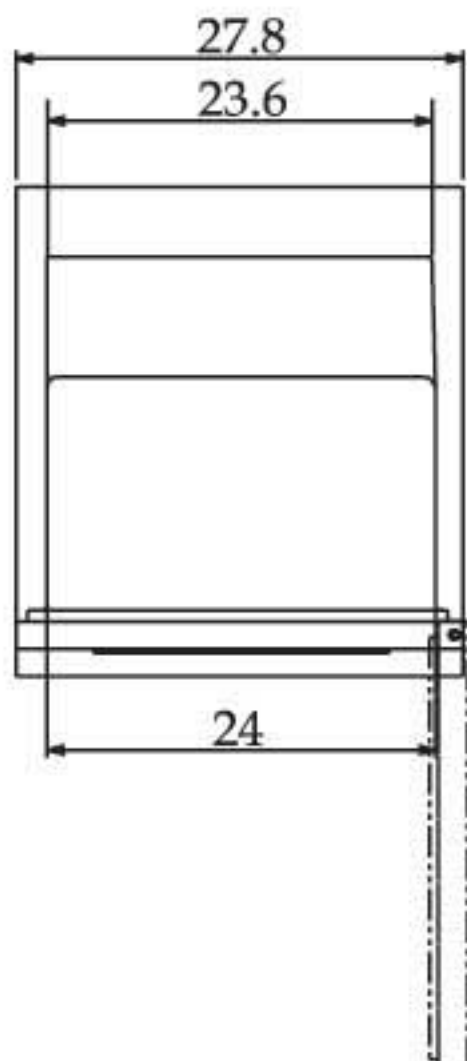

**MUR-28 PLAN VIEW**

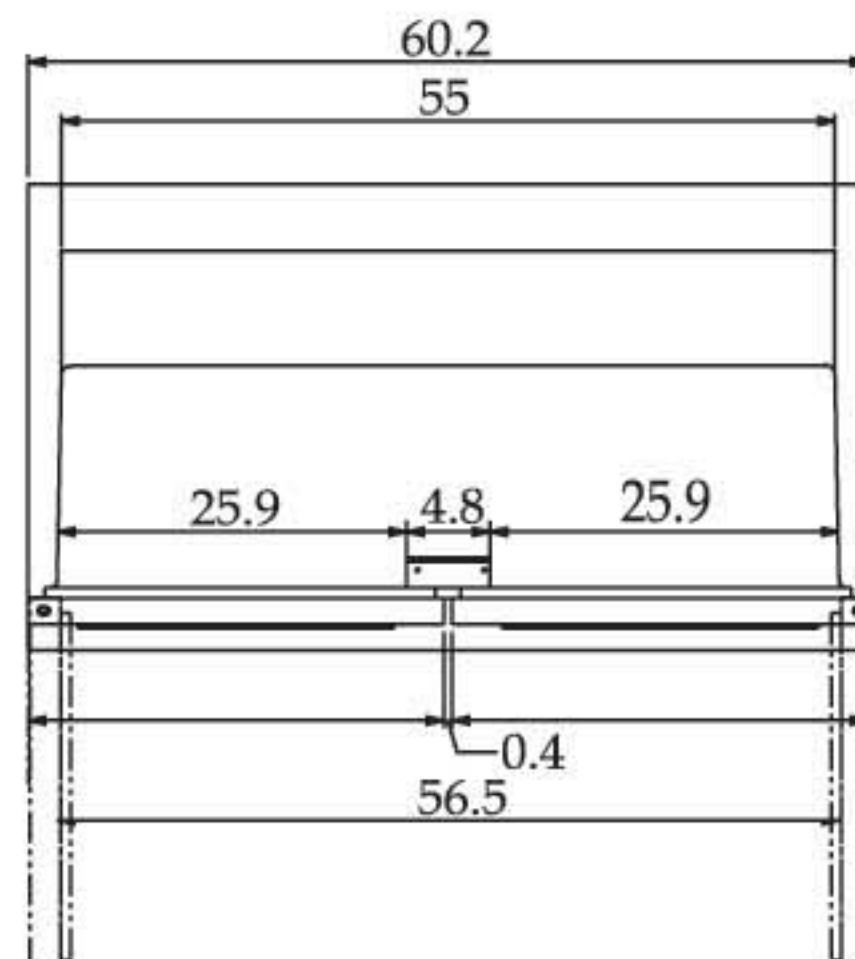

**MUR-60 PLAN VIEW**

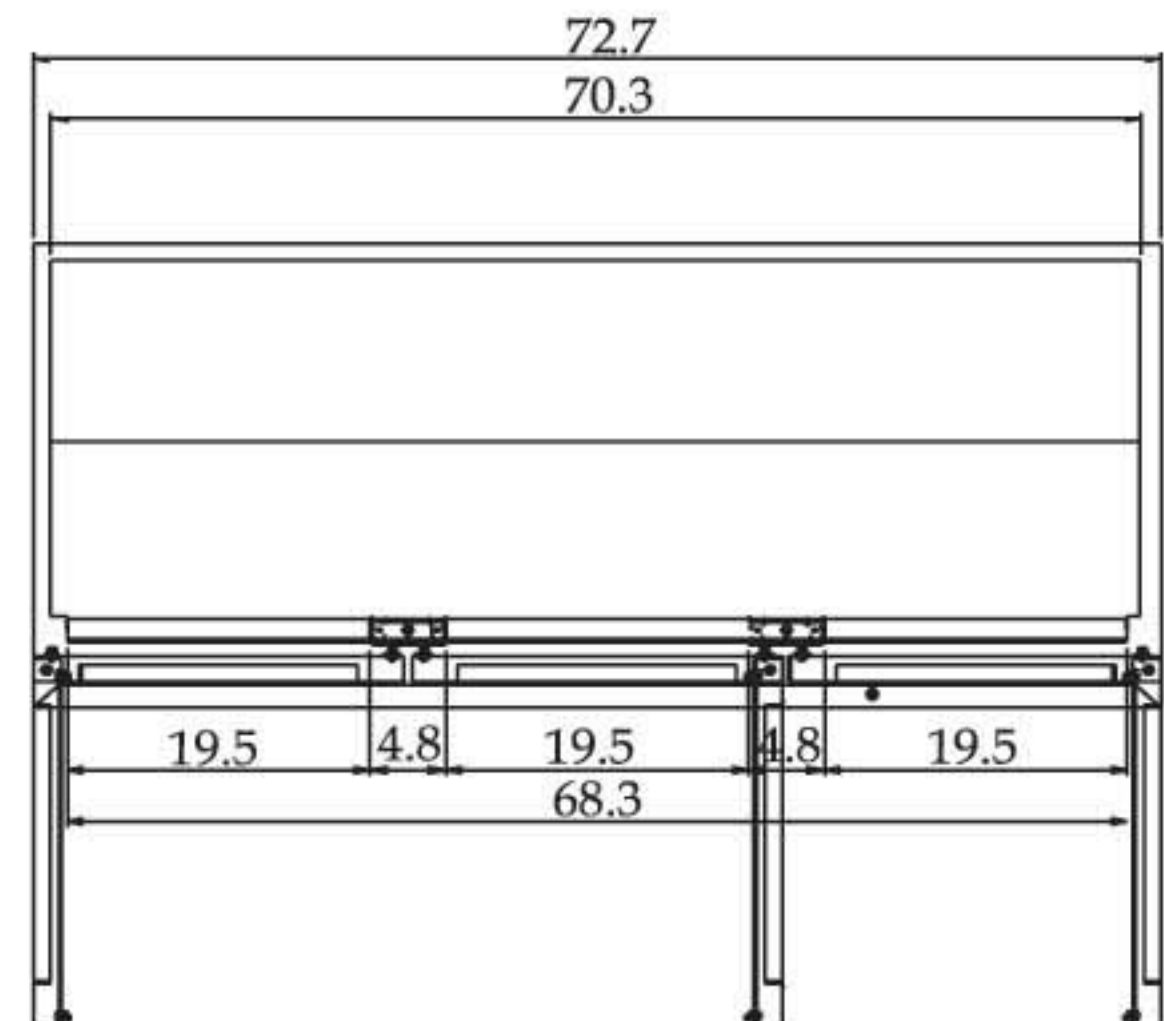

**MUR-72 PLAN VIEW**